

technology Noise Suppression
 Noise reduction characteristics are designed into every major component, reducing in-cab and drive-by noise to levels far below other sweepers in its class.* Efficient fan and nozzle designs allow operator to run at lower RPMs without affecting performance. Fully-encapsulated engine/fan module, special fan inlet, outlet noise attenuator and proprietary insulation system add further reductions.

- 1 High Flow Low-Noise Nozzle**
 Advanced airflow dynamics increase vacuum power while reducing noise. Extends 304 mm (12 in.) from wheel, placing suction power closer to the curb. Direct vacuum path and smooth bore suction hose allow debris to move without interference from turbulence or bends. Pneumatic shutter door with automatic interval settings for easy entry of bulky items and leaves.
- 2 Unique Side Broom Trailing Arms**
 Special 4-way action closely follows road contours while providing break-away safety for obstacles. Digging pressure is adjustable in cab.
- 3 Compact Design**
 Mounts on shorter wheelbases for an extremely tight turning radius and greater maneuverability.
- 4 High Capacity**
 Ample water and hopper capacities for extended sweeping time and maximum productivity. Abrasion-resistant steel deflectors direct debris flow to center of hopper, ensuring even, efficient material loading.
- 5 Powerful Blower with Fluid Coupling**
 High velocity 16 vane design produces unsurpassed sweeping performance. Abrasion-resistant steel blower and housing for extra durability. Maintenance-free fluid coupling for "soft" starts and stops, and minimal noise.
- 6 Comprehensive Water System**
 Controls dust during sweeping and lubricates system against abrasive materials. Spray nozzles are located wherever dust occurs, including side brooms, extension broom and nozzles. Infinitely adjustable water flow with in-cab control of each area. Pressure provided by exclusive Elgin water pump with run-dry capability. Rust-proof, removable tanks are forward-mounted for best weight distribution and axle loading.
- 7 Controls**
 Including all sweep, dump, spray water and hydraulic controls on central rotating console for easy access. Complete gauges (aux. engine coolant temp., oil pressure, charging voltage, engine speed and fuel level) for quick review of system conditions.



High Performance Sweeper Engine
 Heavy-duty diesel with exceptional power, increased fuel efficiency and extended service life. Includes auto shut-down protection for high temp/low oil conditions.

Easy Access Service Module



9 Complete engine access with easy-store ladder and automatic full-width gull-wing doors that open with the turn of a key. Forward-located, ground-level fluid drains simplify fluid changes during service and maintenance.

* As measured per SAE/ISO 6393 hemispherical tests

GeoVac 4 Wheel Vacuum Air Sweeper

<p>Sweep System High performance pure vacuum 2.5 meter (8.25 ft.) sweep path 711 mm (28 in.) side brooms 1524 mm (60 in.) extension broom</p> <p>Nozzle Design High flow, low noise 1119 cm² (174 sq. in.)</p>	<p>Chassis Wheelbase Min. 3200 mm (126 in.)</p> <p>Min. Usable Cab-to-Axle 2500 mm (98.4 in.)</p> <p>Hopper Capacity 6 cu. meters (8 cu. yd.)</p> <p>Water Capacity 1250 L (330 gal.)</p> <p>Blower Rating 441 m³/min. (15,560 CFM)</p>
---	---

Quiet Strength

The Elgin GeoVac sets new world standards by uniting high performance pure vacuum sweeping with incredibly low dB(A) in-cab and drive-by noise levels.



With its exclusive high-flow nozzle design and *e technology* noise reduction system,



GeoVac engineers have combined high pickup efficiency with low noise emissions, creating the most environmentally- friendly sweeping solution in the world. In addition, its

compact design can mount on 3378 mm (133 in.) wheelbase chassis for exceptional maneuverability, yet still includes generous hopper, water and sweep path capacities for extended sweeping time and maximum productivity.



GeoVac 4 Wheel Vacuum Air Sweeper

Options



Stainless Steel Hopper Screens
A variety of high quality 304 stainless steel options are available including hopper floor and sides, hopper door and hopper screens. Stainless steel resists corrosion and enhances hopper dumping.



Operator friendly controls
Ergonomically designed center console provides high visibility, ease of use, and intuitive placement of commonly used controls and gauges.



Wandering Hose
Catch basins and hard to reach places can easily be cleaned using the wandering hose with optional multiple extensions. The 203 mm (8 in.) hose is engaged from the cab. Push buttons mounted on the suction nozzle control blower speed and the hydraulically assisted up and down movement of the nozzle. Optional manhole cover lift also available.

Vehicle width 2438 mm (96 in.)

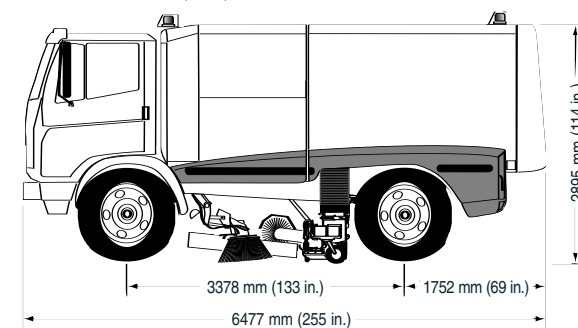

Additional Options

- Dual Sweep (left or right)
- Side broom tilt
- High pressure washdown
- Epoxy coated hopper
- Front spray bar
- Rotating beacon or strobe light
- Light protectors
- Air conditioning
- Automatic lubrication system
- Euro-style trim

Value-Added Services

- Elgin's commitment to the customer continues long after the sale.
- On-time delivery
 - Factory-trained worldwide dealer network
 - Genuine Performance Matched Parts
 - Elgin Training Center
 - Customized leasing and financial services
 - Highest resale value in the industry

Warranty

Elgin Sweeper Company backs the GeoVac sweeper with a one-year limited warranty. The GeoVac is warranted against defects in material or workmanship for a period of 12 months from the date of delivery to the original purchaser. Optional extended warranty packages are available. Consult your Elgin dealer for complete warranty information. The ESCO/FSM warranty shall not apply to major components or trade accessories such as but not limited to, trucks, engines, hydraulic pumps and motors, tires and batteries that have a separate warranty by the original manufacturer.

Your local Elgin Dealer is:

Photo illustrations in this brochure include optional components. Specifications subject to change without notice. Elgin® and GeoVac® are registered trademarks of Elgin Sweeper Company. Effective 1/06 P/N 0705242F Printed in U.S.A. ©2003 Federal Signal Corporation Federal Signal Corporation is listed on the NYSE by the symbol FSS.



Elgin Sweeper Company
Subsidiary of Federal Signal Corporation
1300 W. Bartlett Road
Elgin, Illinois, U.S.A. 60120-7529
(847) 741-5370 Phone
(847) 742-3035 Fax
www.elginsweeper.com