

## Eagle 4 Wheel Broom Sweeper

If you need a proven broom sweeper with high dump capability, superior operator comfort and safety at highway transport speed, the Elgin Eagle® is the solution. With its exclusive No Jam conveyor, wide sweep path and trouble-free lift mechanism, the Eagle provides unequalled productivity in a variety of applications, including road construction and resurfacing.



### 1 No Jam Debris Conveyor

Features molded-in full-width cleats that move large debris without jamming. High-strength belt material provides long wear and maximum uptime. Controlled from cab, including reverse. Built-in washdown for quick, easy cleanup.

### 2 Wide Sweeping Path

Hydraulically-driven main and side brooms create wide 10 ft. (3048 mm) sweeping path for maximum productivity.

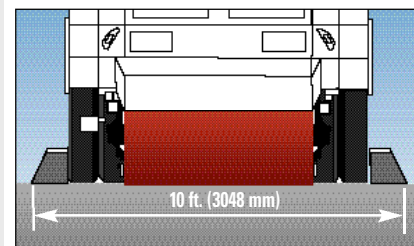

### 3 Patented Air Bag Suspension

Provides fully sprung rear axle for transport comfort, plus solid axle for superior sweeping and stable dumping operations.

### 4 Fully-Sprung Side Brooms

Exclusive trailing arm design and four-way spring mounted movement (side-to-side, up-and-down) minimize broom damage while maximizing surface contact and efficiency. Large 42 in. (1067 mm) brooms provide maximum digging power.

### 5 Variable High Dump Hopper

Unloads at any point from chassis level to 10 ft. (3048 mm). Hopper lifts on trouble-free, twin hydraulic cylinder, dual stage mechanism. Center position keeps weight between dual tires during dumping operations and maintains proper weight distribution as sweeper loads. Load is clearly visible through Lexan window.

### 8 Easy In-Cab Operation

Center-mounted console provides access to all sweeper controls from either driving position. Includes hopper, conveyor, rear suspension, adjustable water and broom controls, plus full load indicator. Broom speed, conveyor speed and digging pressure are adjustable independently of truck RPM. Reverse gear automatically raises sweeping components to prevent damage.

### 9 Minimal Noise Levels

Cab, chassis and sweeping system designed for low in-cab and drive-by noise levels, providing maximum operator comfort and safety.

### 10 Proven Cab-Over Chassis

High visibility commercial-grade cab dualized with genuine OEM parts. Fully sprung chassis minimizes rough road conditions and maximizes operator comfort and control. Complies with FMVSS standards.

### 11 Helpful Maintenance Features

Four access doors (with locks) open wide for easy access to all sweep system components and auxiliary engine. Built-in steps and steel service platform provide stable work surfaces.

### Corrosion-Resistant Water System

Minimizes dust generation by spraying directly at the source. Large 280 gallon (1060 L) capacity maximizes sweeping time. System includes long-life run-dry pump, polyethylene tanks, brass fittings and nozzles, and anti-siphon fill.

### 6 High Capacity Tool Box

Lockable 23 in. W x 30 in. H x 74 in. D (584 mm W x 762 mm H x 1880 mm D) box safely carries and stores your tools, including shovels and rakes.

### 7 Dual Diesel Engine Design

Powerful yet economical performance. Dedicated sweep system engine produces superior digging at required ground speed. Truck engine RPM or ground speed do not affect broom or conveyor speed.



## Options



### Front Spray Bar

Cab controlled water spray bar helps settle debris under extremely dusty conditions. Constructed from corrosion-resistant copper pipe and brass nozzles (4).



### In-Cab Side Broom Tilt

Allows operator to sweep effectively in variably-pitched gutters. On-the-go pitch adjustment with a simple variable rocker switch ensures proper broom angle.

## Additional Options

- Rotating beacon or strobe light
- Rotating beacon/strobe light guard
- Air conditioner
- Carbide dirt shoes
- Arrowboard
- Auto-Lube™ automatic lubrication system
- Automatic engine shutdown (high temperature/low pressure)
- Lifeliner®
- Silicone hoses on auxiliary engine
- Extended side broom reach
- Main broom hour meter
- Side broom position indicators
- One-touch sweep resume system
- Alternative Fuel

## Hopper Side Shift

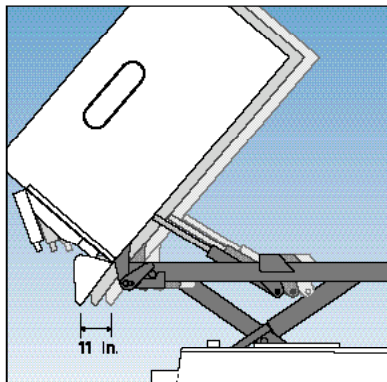

Up to 11 in. (279 mm) of side shift allows greater truck mirror/container clearance and extends hopper reach into container.

## Dimensions

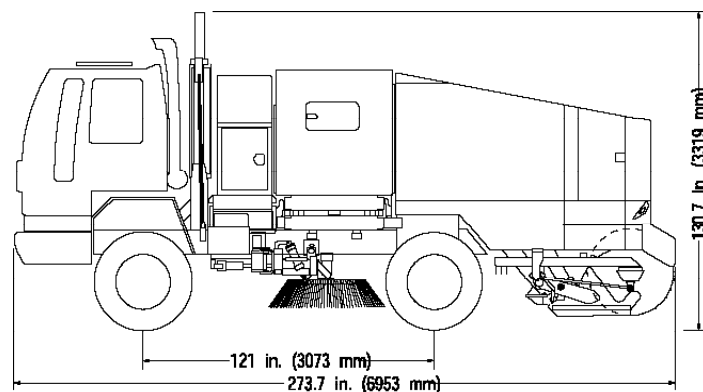

## Value-Added Services

Elgin's commitment to the customer continues long after the sale.

- Factory-trained worldwide dealer network for assistance with service and maintenance
- Genuine Performance Matched Parts
- Elgin Training Center with hands-on instruction for operators and service personnel
- Customized leasing and financial services

## Warranty

Elgin Sweeper Company backs the Eagle sweeper with a one-year limited warranty. The Eagle is warranted against defects in material or workmanship for a period of 12 months from the date of delivery to the original purchaser. Optional extended warranty packages are available. Consult your Elgin dealer for complete warranty information.



Elgin Sweeper Company  
Subsidiary of Federal Signal Corporation  
1300 W. Bartlett Road  
Elgin, Illinois, U.S.A. 60120-7529  
(847) 741-5370 Phone  
(847) 742-3035 Fax  
[www.elginsweeper.com](http://www.elginsweeper.com)

Eagle® 4 Wheel Broom Sweeper

ELGIN®

